

*70x140 70x160*

*80x140 80x160*

*80x180 80x190*

*80x200*

*90x140 90x160*

*90x180 90x190*

*90x200*



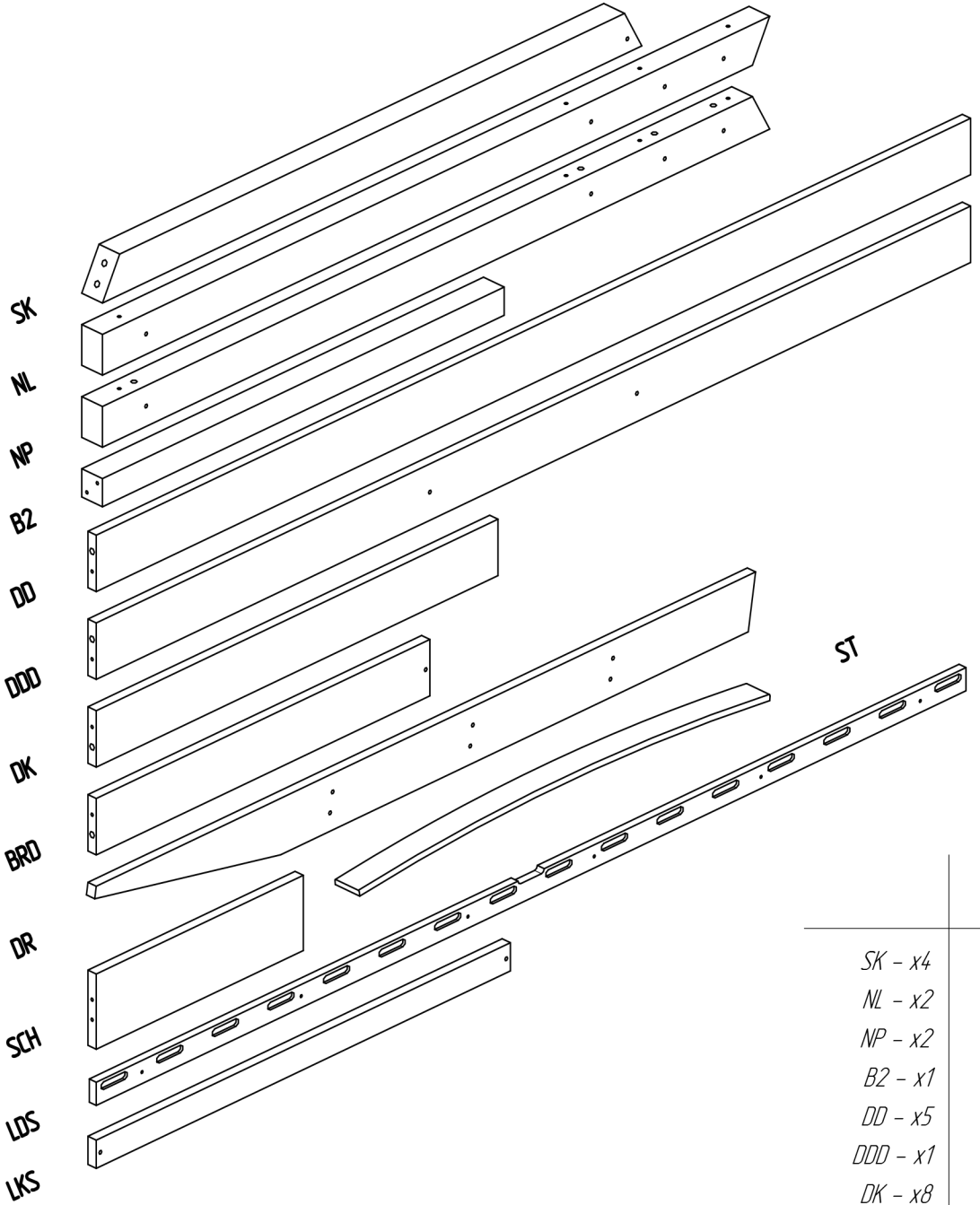

- SK - x4
- NL - x2
- NP - x2
- B2 - x1
- DD - x5
- DDD - x1
- DK - x8
- BRD - x4
- DR - x2
- SCH - x3
- LDS - x4
- LKS - x2
- ST - x24-32

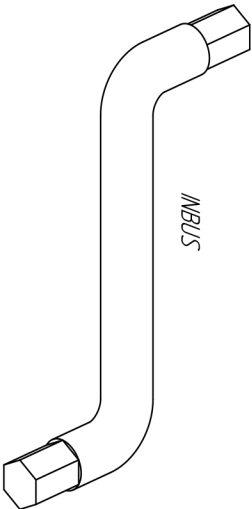
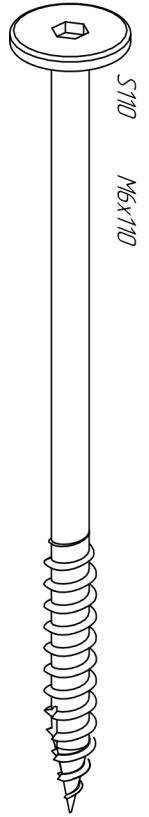
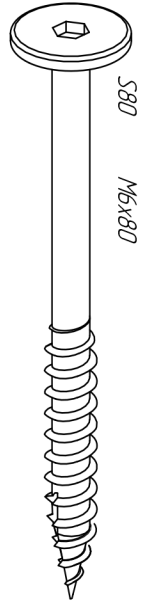
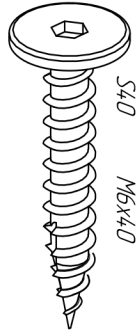
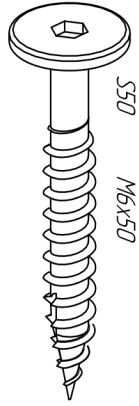
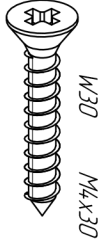
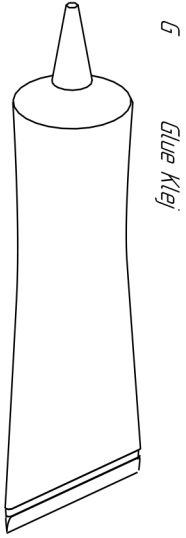

*S110 - x16*

*S80 - x20*

*S50 - x14*

*S40 - x4*

*W30 - x28*

*K10 - x46*

*G - x4*

*INBUS - x1*

# Quantity of holes for mattress bar and number of ST part.

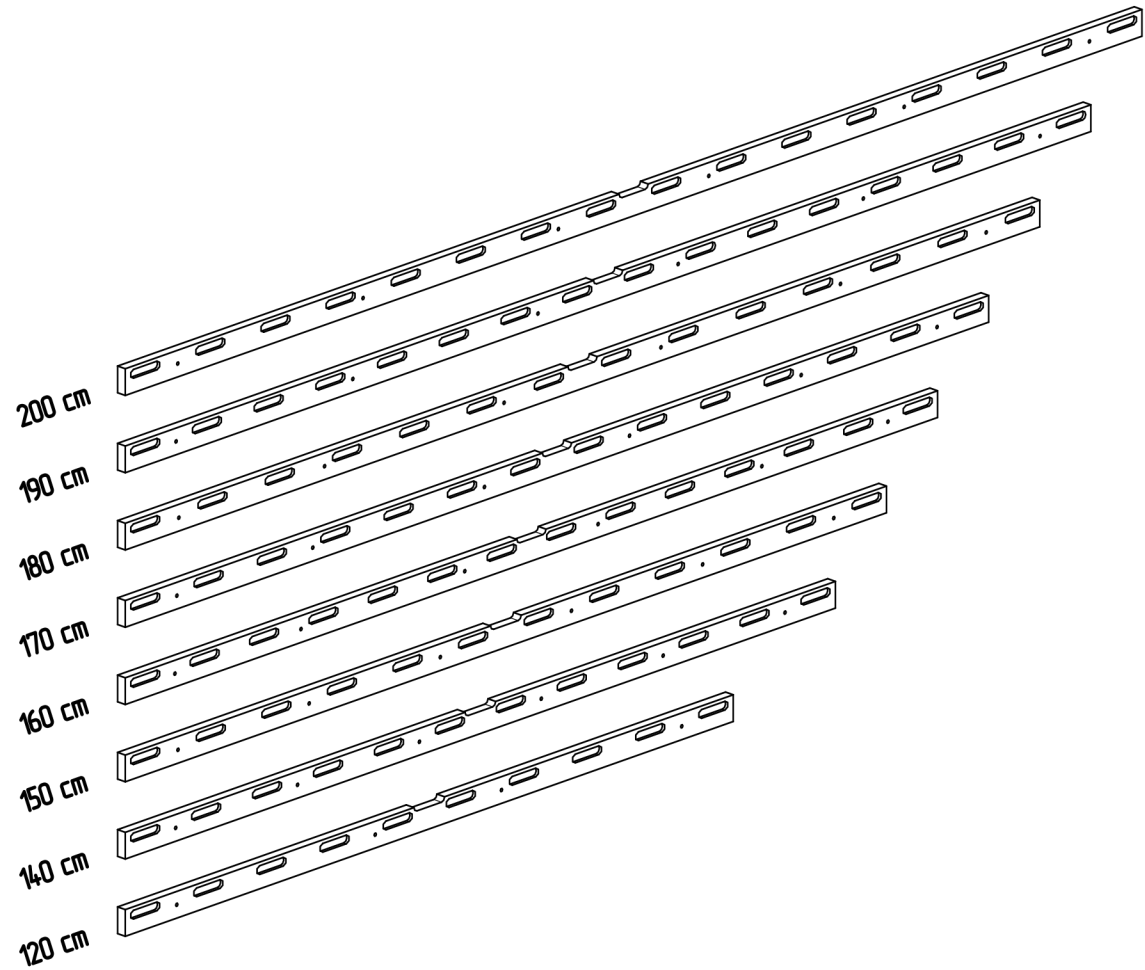

<i>Length</i>	<i>QT</i>
---------------	-----------

<i>200 cm</i>	<i>16</i>
---------------	-----------

<i>16</i>
-----------

<i>190 cm</i>	<i>16</i>
---------------	-----------

<i>16</i>
-----------

<i>180 cm</i>	<i>14</i>
---------------	-----------

<i>14</i>
-----------

<i>170 cm</i>	<i>14</i>
---------------	-----------

<i>14</i>
-----------

<i>160 cm</i>	<i>14</i>
---------------	-----------

<i>14</i>
-----------

<i>150 cm</i>	<i>12</i>
---------------	-----------

<i>12</i>
-----------

<i>140 cm</i>	<i>12</i>
---------------	-----------

<i>12</i>
-----------

<i>120 cm</i>	<i>10</i>
---------------	-----------

<i>10</i>
-----------

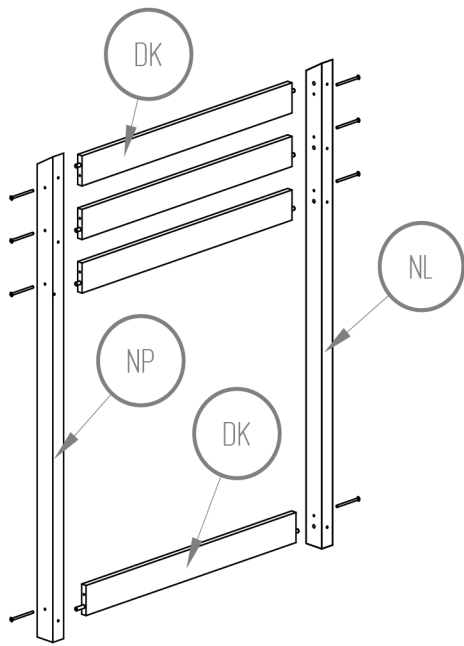
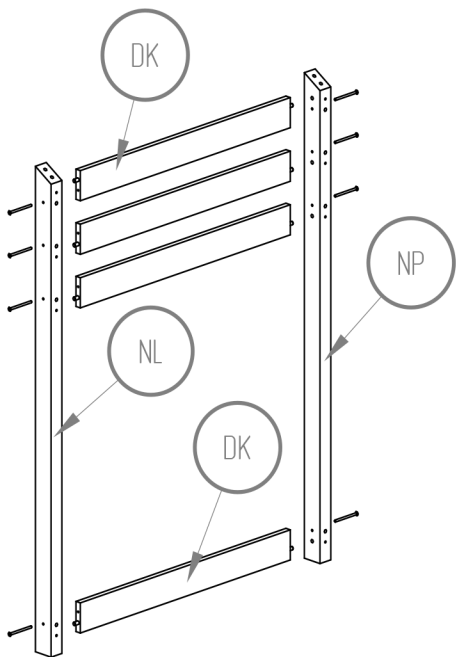
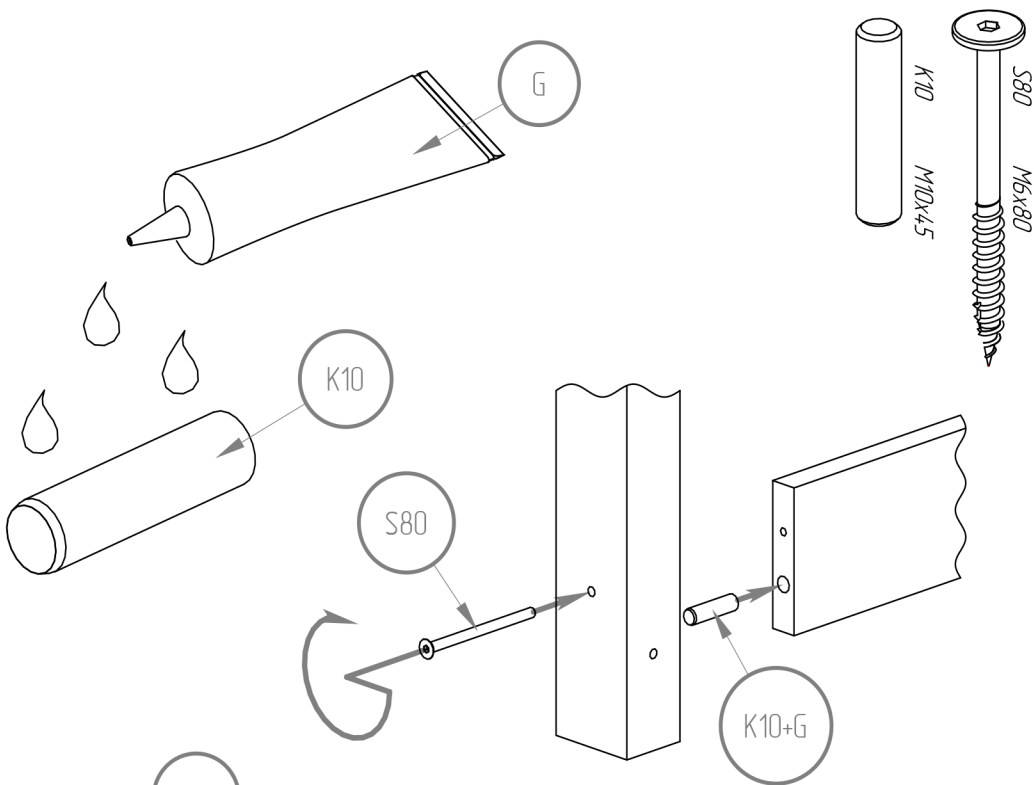

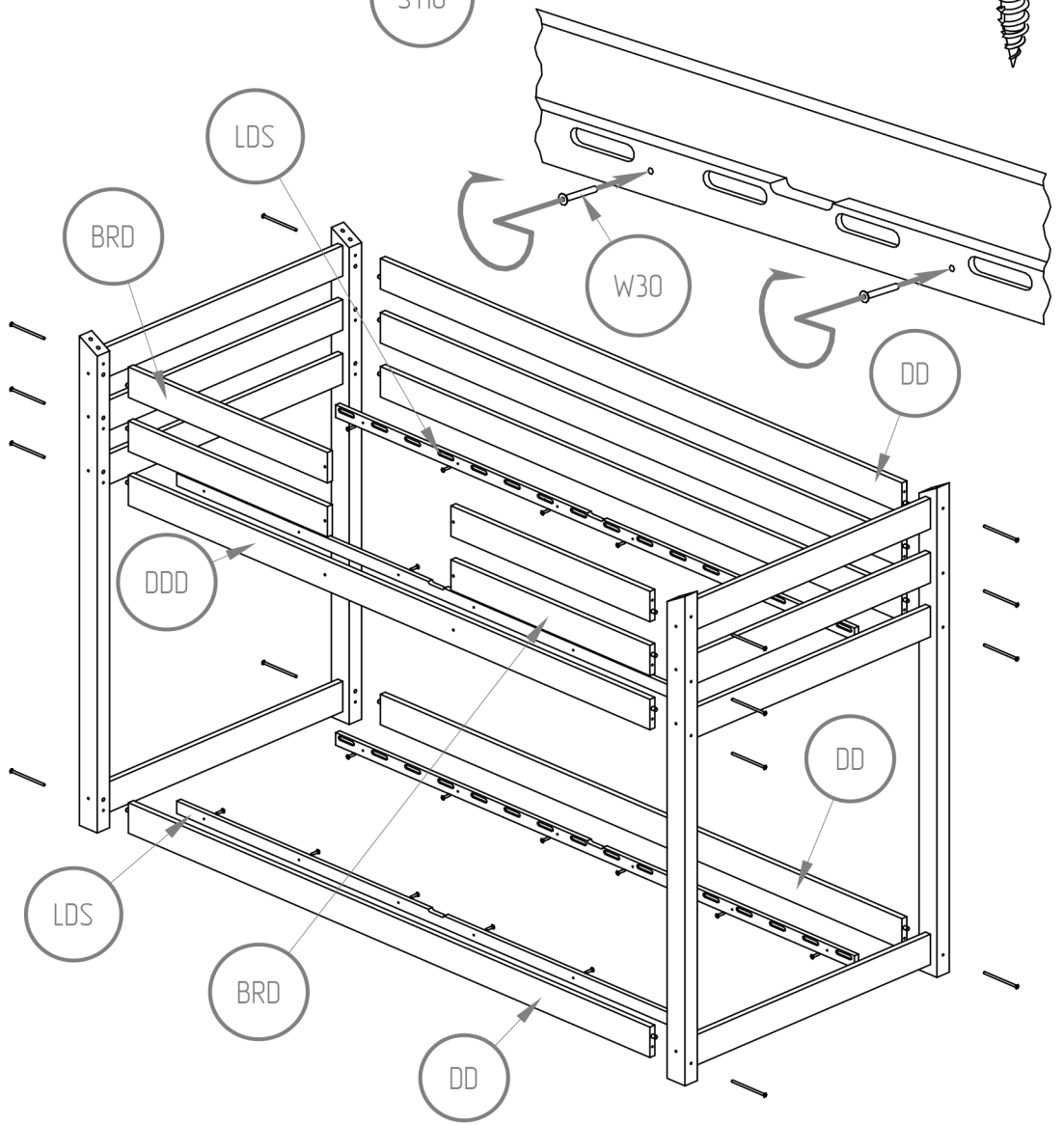
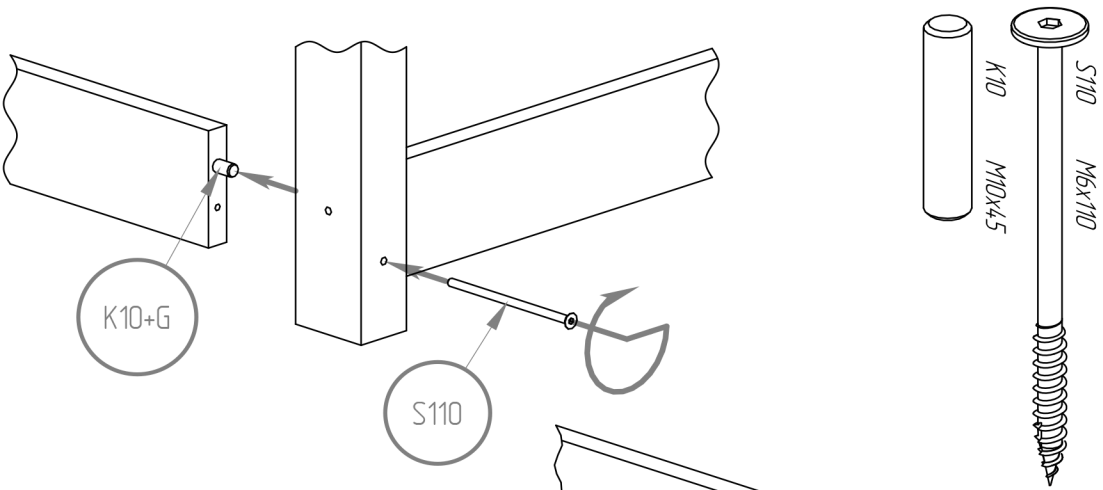

K10  
M10x45

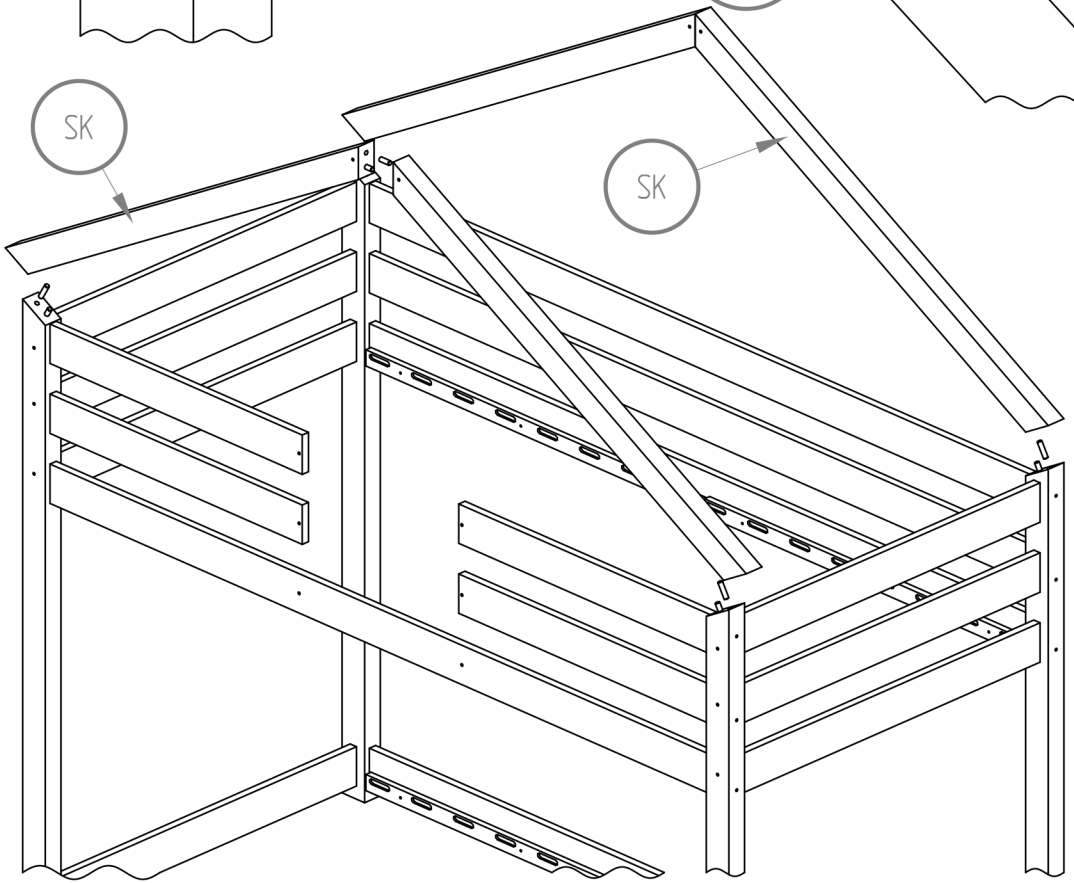
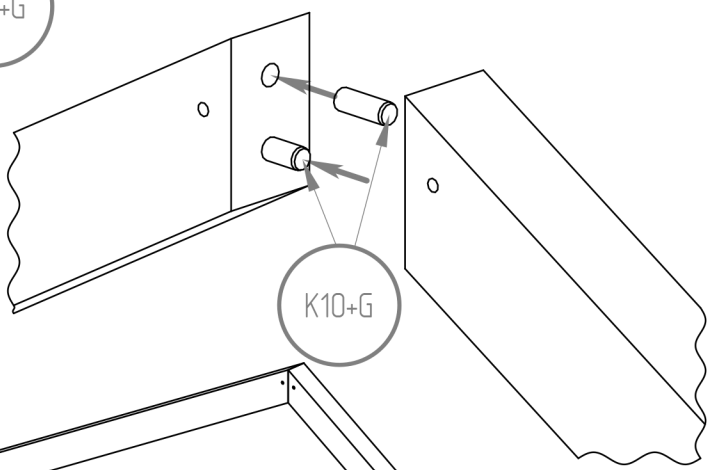
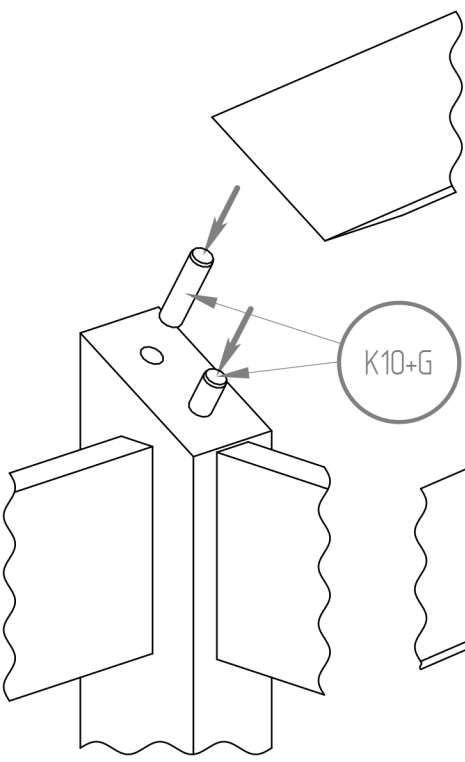

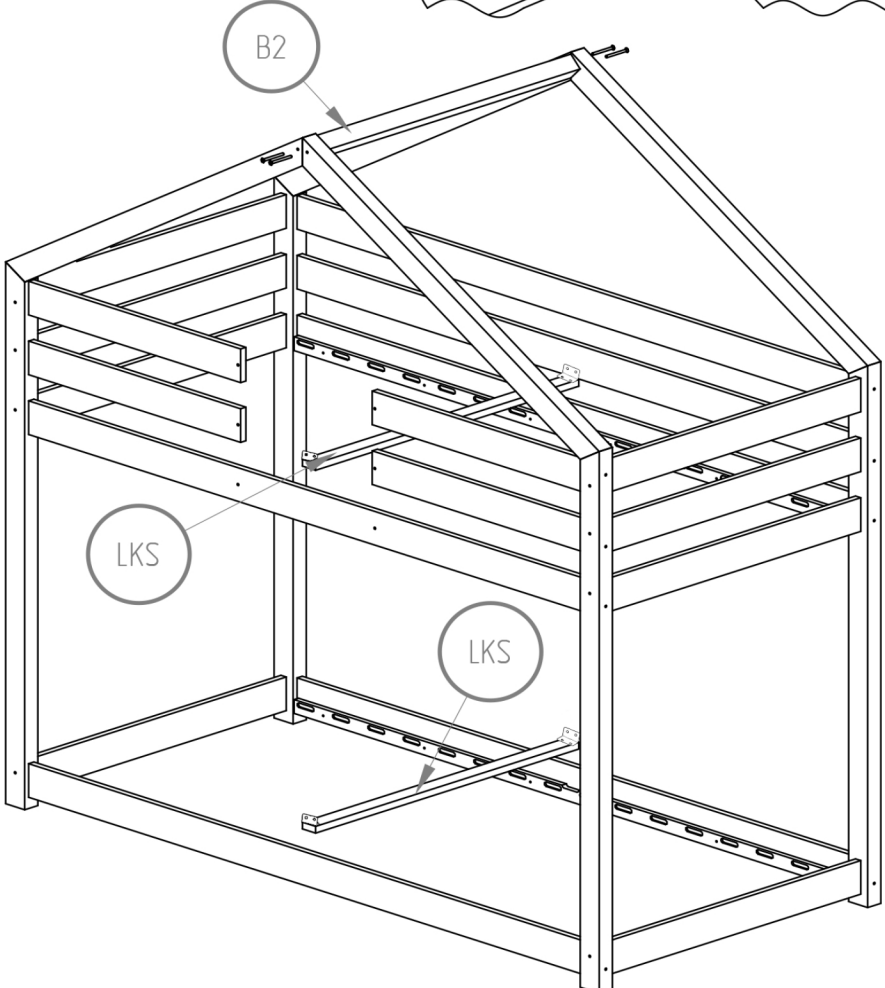
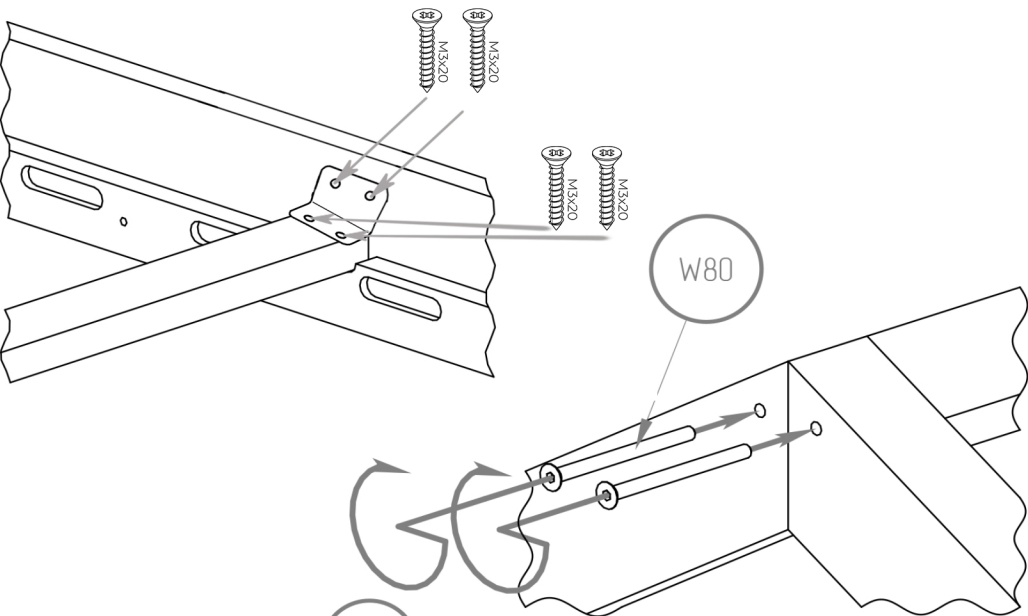
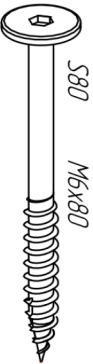



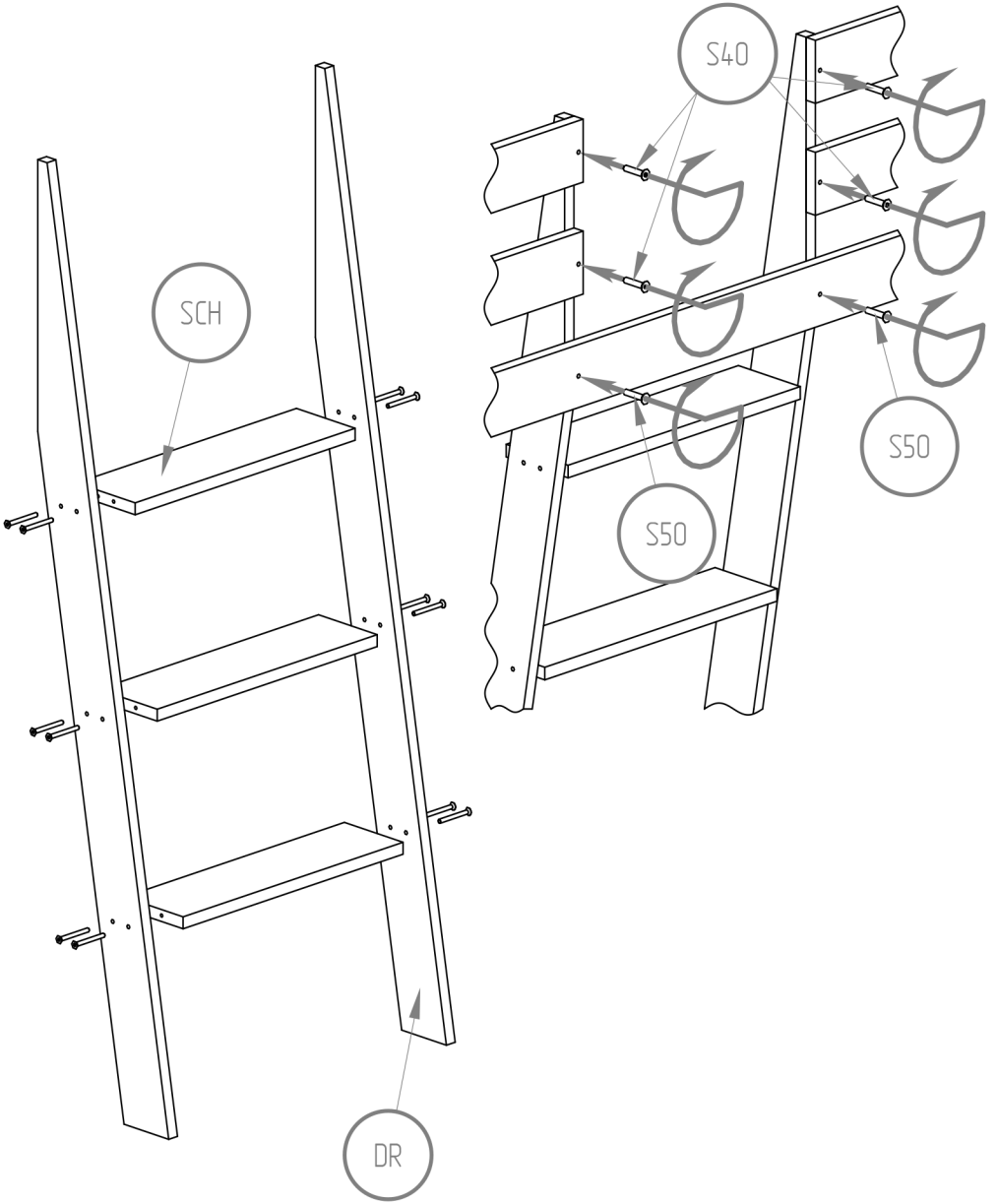
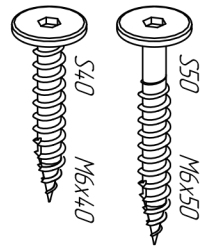
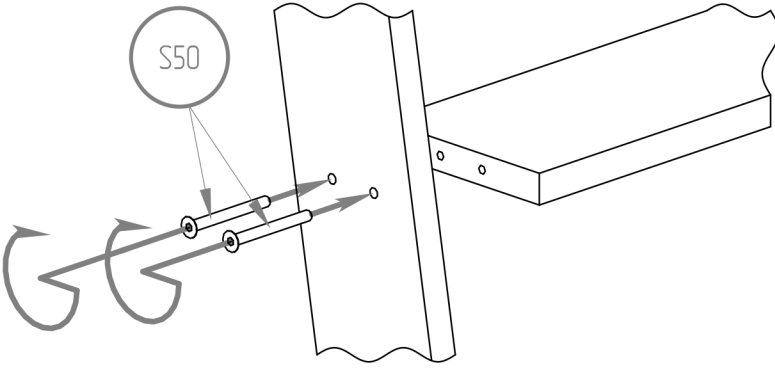

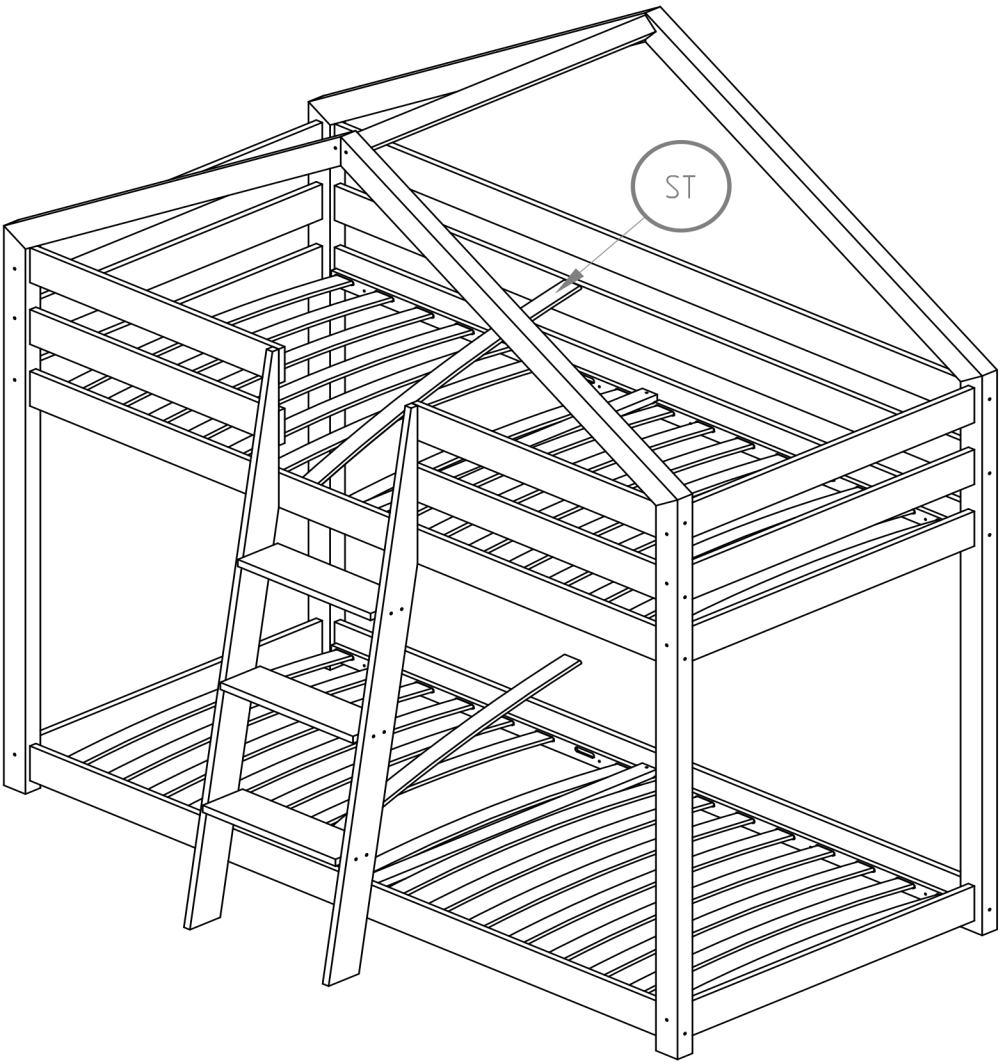
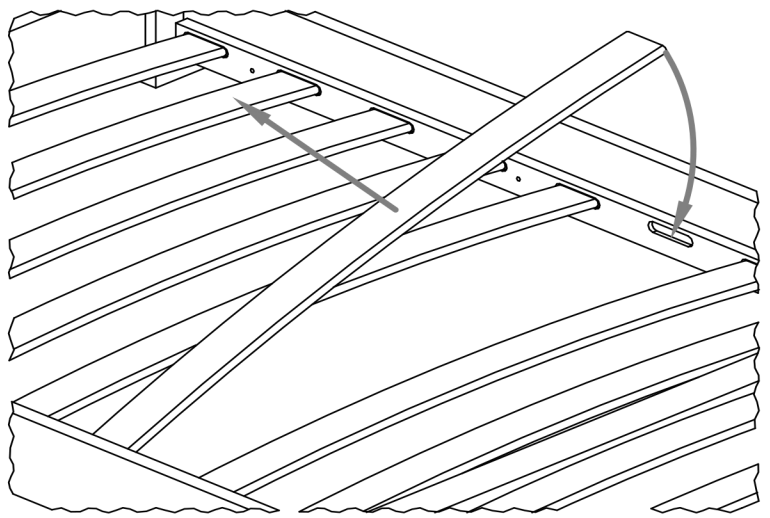



*NIE SKAKAĆ*

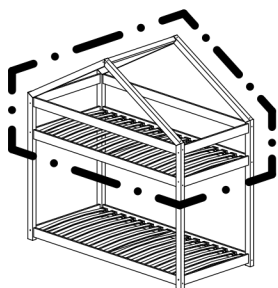

*Górne tóżko dla dzieci powyżej 6 roku życia.*

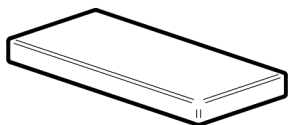

*Wysokość materaca:*

*min. 8 cm*

*max. 12 cm*



---

## *UWAGA !*

---

*ABY ZAPOBIEC POWAZNYM URAZOM I USZKODZENIOM*

*CIAŁA NALEŻY:*

- Nigdy nie pozwalać dzieciom poniżej 6 roku życia przebywać na górnej pryczy.*
- Używać tylko materacy o grubości 8-12 cm.*
- Używać poręczy po obu stronach górnej pryczy.*
- Nie skakać na lub pod tóżkiem (tóżkach).*
- Zakazywać przebywania więcej niż jednej osoby na górnym tóżku.*
- Używać drabiny, aby wejść i wyjść z górnej pryczy.*
- Nie wieszać się na elementach konstrukcyjnych.*

*Części drewniane i plastikowe należy czyścić za pomocą suchej szmatki oraz zwykłych, łagodnych środków do pielęgnacji i czyszczenia surowego drewna.*

*Zaprojektowano i wykonano zgodnie z normą:*

*PN-EN 747-1+A1:2015-08*

*NIEBEZPIECZEŃSTWO ZAGROŻENIA – Nigdy nie podłączaj ani nie zawieszaj przedmiotów do jakiegokolwiek części tóżka piętrowego, do której nie są przeznaczone.*

*CERTYFIKAT – To tóżko piętrowe jest zgodne ze wszystkimi obowiązującymi standardami bezpieczeństwa produktów konsumpcyjnych.*

*Numer certyfikatu: OBAC / 0251 / CZ / 18*



*NO JUMPING*

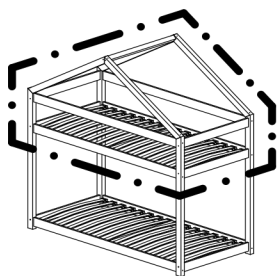

*Upper bed for  
children 6+ years old*

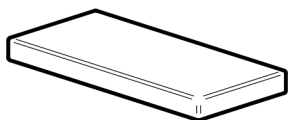

*Mattress height:*

*min. 8 cm*

*max. 12 cm*



---

## *WARNING !*

---

*TO HELP PREVENT SERIOUS OR FATAL INJURIES FROM  
ENTRAPMENT OF FALLS:*

- Never allow a child under 6 years on upper bunk.*
- Use only mattress with thickness is 8-12 cm height.*
- Use guardrails on both sides of upper bunk.*
- Prohibit horseplay on or under bed(s).*
- Prohibit more than one person on upper bunk.*
- Use ladder for entering and leaving upper bunk.*
- Do not hang on construction components.*

*Wooden and plastic parts should be cleaned with a  
dry cloth and ordinary, mild care and cleaning of raw  
wood.*

*Designed and made according to the standard:  
PN-EN 747-1+A1:2015-08*

*STRANGULATION HAZARD - Never attach or hang  
items to any part of the bunk bed that are not  
designed for use with the bed.*

*CERTIFIED - This bunk bed conforms to all applicable  
consumer product safety standards.*

*Number of certificate: OBAC/0251/CZ/18*